

NovAseptic[®] Connector According to PED, Tube Standard ASTM[®] A270

Catalogue Number NAC-A###/Height

According to PED, Tube Standard ASTM[®] A270 Configuration

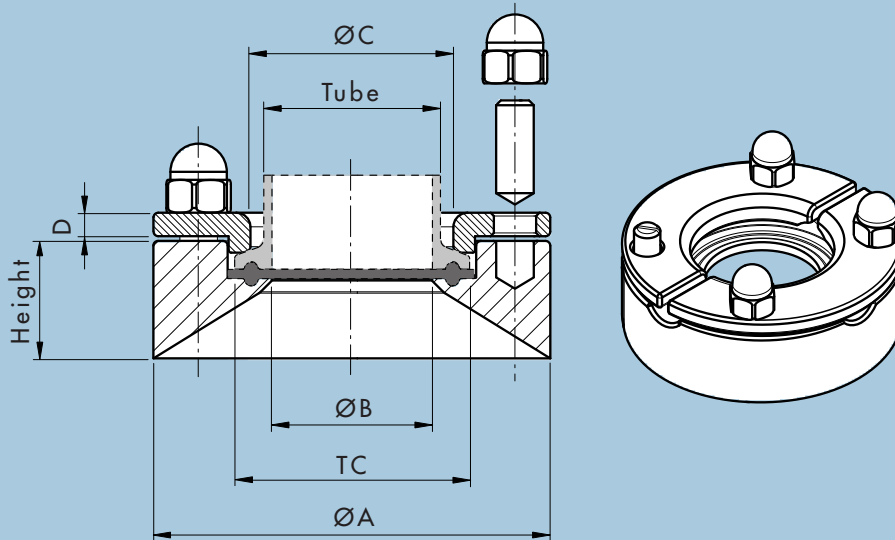

Nominal Dimensions in mm (in.)

NAC-A###/	Height	Tube	TC	A	B	C	D	Acorn Nut Size	Stud Size
NAC-A038/	12	9.53 (0.375)	25	55.0 (2.165)	7.0 (0.276)	20.0 (0.787)	5.0 (0.197)	M6	M6x16
	25								
	38								
	51								
NAC-A050/	12	12.7 (0.500)	25	55.0 (2.165)	9.4 (0.370)	20.0 (0.787)	5.0 (0.197)	M6	M6x16
	25								
	38								
	51								
NAC-A075/	12	19.05 (0.750)	25	55.0 (2.165)	15.75 (0.620)	20.0 (0.787)	5.0 (0.197)	M6	M6x16
	25								
	38								
	51								
NAC-A100/	12	25.4 (1.000)	50.5	85.0 (3.346)	22.1 (0.870)	43.8 (1.724)	5.0 (0.197)	M8	M8x20
	25								
	38								
	51								
NAC-A150/	12	38.1 (1.500)	50.5	85.0 (3.346)	34.8 (1.370)	43.8 (1.724)	5.0 (0.197)	M8	M8x20
	25								
	38								
	51								
NAC-A200/	15	50.8 (2.000)	64	100.0 (3.937)	47.5 (1.870)	55.0 (2.165)	6.0 (0.236)	M8	M8x20
	25								
	38								
	51								
NAC-A250/	15	63.5 (2.500)	77.5	112.0 (4.409)	60.2 (2.370)	65.5 (2.579)	9.5 (0.374)	M8	M8x25
	25								
	38								
	51								
NAC-A300/	15	76.2 (3.000)	91	131.0 (5.157)	72.9 (2.870)	78.0 (3.071)	10.0 (0.394)	M8	M8x25
	25								
	38								
	51								
NAC-A400/	15	101.6 (4.000)	119	170.0 (6.693)	97.4 (3.835)	105.0 (4.134)	12.0 (0.472)	M8	M8x30
	25								
	38								
	51								

Specifications

Net Weight (approximate)

Connector	NAC-A038/				NAC-A050/				NAC-A075/				NAC-A100/				NAC-A150/			
	12	25	38	51	12	25	38	51	12	25	38	51	12	25	38	51	12	25	38	51
Weight kg (lb)	0.3 (0.66)	0.4 (0.88)	0.6 (1.3)	0.7 (1.5)	0.3 (0.66)	0.4 (0.88)	0.5 (1.1)	0.7 (1.5)	0.2 (0.44)	0.4 (0.88)	0.5 (1.1)	0.6 (1.3)	0.6 (1.3)	0.9 (2.0)	1.2 (2.65)	1.5 (3.31)	0.6 (1.3)	0.8 (1.8)	1.1 (2.43)	1.4 (3.09)

Net Weight (approximate)

Connector	NAC-A200/				NAC-A250/				NAC-A300/				NAC-A400/			
	15	25	38	51	15	25	38	51	15	25	38	51	15	25	38	51
Weight kg (lb)	0.8 (1.8)	1.1 (2.43)	1.4 (3.09)	1.8 (3.97)	1.1 (2.43)	1.4 (3.09)	1.8 (3.97)	2.2 (4.85)	1.5 (3.31)	1.8 (3.97)	2.3 (5.07)	2.9 (6.39)	2.5 (5.51)	3.1 (6.83)	3.9 (8.60)	4.8 (10.6)

Material

	Welding Flange Stainless Steel in Compliance with		Locking Ring Stainless Steel in Compliance with		Bolt and Nut Stainless Steel in Compliance with	
Material Code	316L		EN 1.4435		EN 1.4404	
Technical Requirements	ASME® SA-479		EN 10272		EN 10272	

Specifications

Surface Roughness:	Internal surface (manually polished) $Ra \leq 1.6\mu\text{m}$ (63 μin)
Design Temperature:	-80 to 200 °C (-112 to 392 °F)
Design Pressure:	-1 to 7 bar(g) (-14.5 to 101 psi(g))
Note!	The applied gasket (not included) may have different design temperature and/or pressure limits than the NovAseptic Connector. The weakest component in the assembled product determines the maximum design temperature and pressure limits.
Labeling:	Each NovAseptic Connector is labeled for full LOT traceability and heat No. according to Millipore QA routines.
Packaging:	All open ends on the NovAseptic Connector are protected with plastic covers on delivery. The NovAseptic Connector is pre-assembled and packaged in a closed box.
Quality Control:	Millipore Quality Assurance System guarantees the control and traceability at all stages of the manufacturing.
In Compliance With:	The NovAseptic Connector does comply for Europe with the relevant requirements in Annex I, Essential Safety Requirement in PED Directive 97/23/EC and AD 2000. The equipment has been examined with respect to the relevant parts for design examination procedure of conformity assessment as described in Module B in the AFS 1999:4 (PED Directive 97/23/EC), by Notified Body.
Options:	For non-standard NovAseptic Connector Options, please contact Millipore for further information.

To Place an Order or Receive Technical Assistance

For additional information call your nearest Millipore office or visit us at www.millipore.com.
In the U.S. and Canada, call toll-free 1-800-MILLIPORE (1-800-645-5476). In the U.S., Canada and Puerto Rico, fax orders to 1-800-MILLIFX (1-800-645-5439).

MILLIPORE

Millipore and NovAseptic are registered trademarks of Millipore Corporation or an affiliated company.
ASME is a registered trademark of the American Society of Mechanical Engineers.
ASTM is a registered trademark of the American Society for Testing and Materials.
Specifications subject to change without notice.
Lit. No. SP1163EN00 Rev. -, 10/2006. Replaces DS-246
© 2006 Millipore Corporation. All rights reserved.