

文件管制

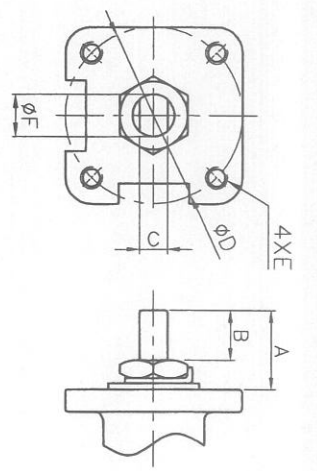
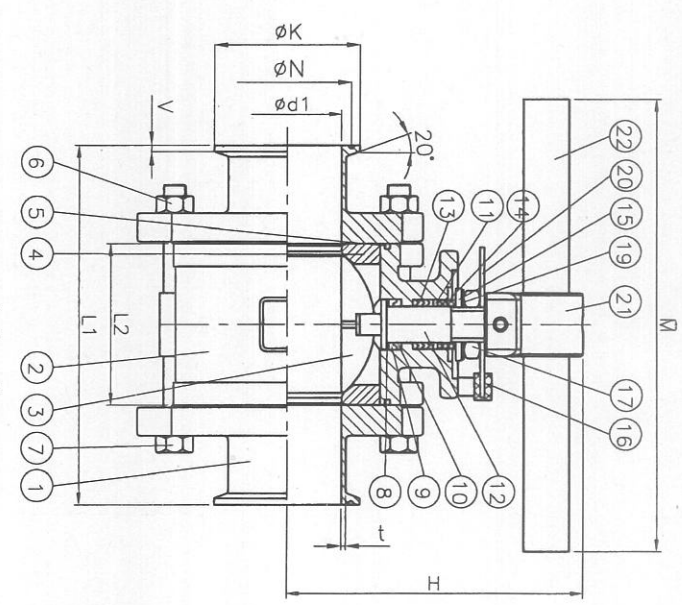
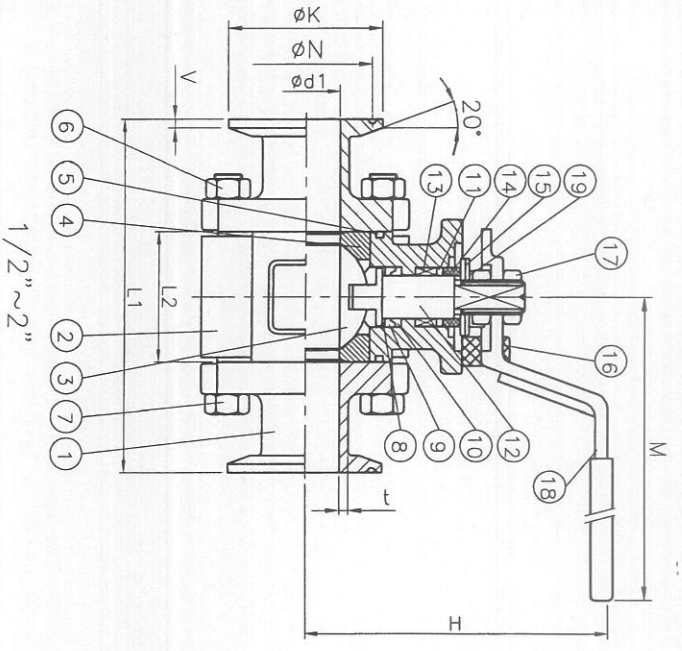

*1/2"~2-1/2"x4, 3"~4"x6
#:1/2"~2"x4, 2-1/2"x8, 3"~4"x12

SIZE	A	B	C	ØD	E	ØF	M	H	V	L1	L2	ØK	ØN	Ød1	t
1/2"	19.8	12.5	6.3	42	M5	12	135	82	3.63	93	26.5	25	20.2	△9.4	3.32
3/4"	20	12.5	6.3	42	M5	12	135	86	3.63	105.2	33.2	25	20.2	△15.75	1.56
1"	21	13.7	8	50	M6	14	165	98	2.85	113.9	37.7	50.4	43.6	△22.1	3
1-1/2"	24.6	13.9	9.5	70	M8	14	200	101	2.85	125	58	50.4	43.6	△34.8	1.95
2"	25.1	13.9	9.5	70	M8	16	200	115	2.85	146	69.6	63.9	56.3	△47.5	2
2-1/2"	41.6	26.1	15	102	M10	16	200	124	2.85	174	86.5	77.4	70.6	△60.2	3.55
3"	42	25.4	15	102	M10	24	250	160	2.85	193	102.6	90.9	83.3	△72.9	3.75
4"	47.8	29.2	17	102	M10	24	250	170	2.85	219.4	118.9	110.3	△97.38	2.8	

NO.	PART NAME	MATERIAL
22	HANDLE	SGP Zn PLATING (2-1/2"~4")
21	HANDLE ADAPTER	CF8
20	TRIANGLE STOPPER	304SS
19	LOCK SADDLE	304SS
18	HANDLE	CF8
17	STEM NUT	304SS
16	STOP BOLT	STAINLESS STEEL
15	BELLEVILLE WASHER	301SS
14	GLAND	304SS
13	V-RING STEM PACKING	PTFE
12	STEM	316SS
11	THRUST WASHER	50% SS/50% PTFE
10	UPPER THRUST WASHER	TFM1600
9	COMPRESS RING	316SS
8	LOWER THRUST WASHER	50% SS/50% PTFE
7	BOLT	A2-70
6	BOLT NUT	A2-70
5	BODY SEAL	PTFE
4	BALL SEAT	PTFE
3	BALL	CF8M
2	BODY	CF8M
1	CAP	CF3M

修改尺寸 Ød1	SAMANTHA 2006/01/19
修改尺寸 9.53 → 9.35	SAMANTHA 2006/01/12
修改尺寸	LINN 03.29'05
修改 2-1/2"~4" 螺絲尺寸 原 M12 改為 M10	LINN 11.25'04
增加尺寸	JOHN 05.03'04
DESCRIPTION	REVISER
CODE	DATE

DATE	2002/06/02	SCALE	N.A.	DRAWN	郭惠芳
PROJECTION	1st	UNIT	mm	SIZE	A4
PART No.	N.A.	CUSTOMER		SHEET	1 / 1
DWG No.	70-T-CLAMP	VERSION			N.A.
TITLE	70T0-1/2"~4"/TRI-CLAMP			CATEGORY	ASSY
TAIWAN VALVE CO., LTD.					