

Conductive Multilevel Sensor

Application

- Level detection of fluid and conductive media in vessels (min. conductivity 1 $\mu\text{S}/\text{cm}$ but depending on the transmitter)

Application Examples

- Full- / empty detection in vessels
- Level control in vessels
- Overflow protection in dosing plants

NVS-345 Hygienic Design

- Hygienic and easy cleanable measurement point (EHEDG permit, 3-A certificate)
- Elastomer free sealing system, the connection will be without gaps and crevices (see product Info 'Process Connection')
- CIP- / SIP-cleanable up to 140 °C
- Food compatible materials according to FDA
- Sensor completely made of stainless steel and PEEK isolation of PFA
- Adapters available for all current process connections

Features

- Defined position of the cable entry
- Available with or without integrated level transmitter
- Individual shortening and twisting of the rod is possible

Options / Accessories

- Version with rope-electrodes available (NVS-110.SEIL)

Selection of the right sensor type

- Coating
For foamy, adhesive (e.g. yoghurt) and wetting media (e.g. alkaline solutions), we suggest to use a sensor with a coated rod. Sensors with bright rod are suitable for watery, not adhesive and not wetting media.
If the rod are longer than 500 mm we also suggest to take coated rods, because long rods may contact each other and cause a wrong output signal

Conditions for a measuring point according to 3-A-Standard 74-03:

- The sensor NVS-345A is approved according to the 3-A-Standard.
- Only with the build-in system CLEANadapt (EMZ, EMK, Adapter AMC, AMV, AMA and AMB) allowed.
- The welding seam by using of EMZ and EMK has to correspond with 3-A-Standard 74-03, D6.1.4: "The minimum radii for fillets of welds in product contact surfaces shall be not less than $\frac{1}{4}$ in. (6.35 mm) except that the minimum radii for such welds may be $\frac{1}{8}$ in. (3.18 mm) when the thickness of one or both parts joined is less than $\frac{3}{16}$ in. (4.76 mm).
- Self draining has to be warranted by the build-in position
- The process connection needs a self-draining leakage hole.



Product Information NVS-345, -50, -110, -120

Specification



NVS-345



NVS-50



NVS-110



NVS-120

Process connection	thread G1" hygienic	diary flange DIN11851 DN50	thread G1" standard	thread G1 1/2" standard
Electrode: quantity	max. 4	max. 5	max. 4	max. 5
length [mm]	200; 500; 850; 1000; 1500; 2000	200; 500; 850; 1000; 1500; 2000	200; 500; 850; 1000; 1500; 2000	200; 500; 850; 1000; 1500; 2000
diameter	4 mm	4 mm	4 mm	4 mm
Temperature*				
process / cleaning	140 °C / 30 min.	140 °C / 30 min.	0...90 °C	0...90 °C
ambient	-10...+60 °C	-10...+60 °C	-10...+60 °C	-10...+60 °C
Pressure	max. 10 bar	max. 10 bar	max. 10 bar option 'SEIL': max. 1 bar	max. 10 bar
Electrical connection				
cable entry				
M16x1,5	yes	yes	yes	yes
M12 plug of 303 (1.4305)	yes	yes	yes	yes
Protection type	IP69K	IP69K	IP69K	IP69K
Material				
connection head	SS 303 (1.4305)	SS 303 (1.4305)	plastic PP Hart	plastic PP Hart
thread	SS 303 (1.4305)	SS 303 (1.4305)	plastic PP Hart	plastic PP Hart
rod / electrode	SS 316L (1.4404)	SS 316L (1.4404)	SS 316L (1.4404)	SS 316L (1.4404)
rope / rope weights	-	-	SS (1.4401) / SS (1.4404)	-
isolator	PEEK	PEEK	-	-
coating (electrodes)	PFA	PFA	PFA	PFA
coating (rope)	-	-	Polyamid PA6	-
Torque	10...20Nm	-	-	-
Rope version possible	no	no	yes (NVS-110.SEIL)	no

* If a level transmitter is integrated, please take care about the temperature specification of the level transmitter (see below).

Level transmitter MNV-1C

Temperature	operating	-10...+60 °C
	storage	-20...+60 °C
Humidity	without condensate	0...95 % r. H.
Power supply		15...36 V DC
Electrode E1	voltage	1,5...2 VAC/300 Hz no DC signal
Sensitivity		
selectable	MNV-1C	0,1; 1; 10; 100 kOhm
Output	short-circuit-proof	active 50 mA
Delay	fix	0,5 s
Switching logic		
min/max selectable	MNV-1C	via jumpers

Calculation of the min. conductivity of the medium

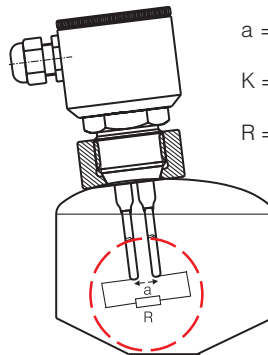

a = shortest absolute length between the electrodes
 K = geometric factor for the distance a (a/cm²)
 R = resistance of the medium
 $R_{max}: NVS-345.2/M = 100 \text{ kOhm}$

Electrical connection and configuration of level transmitter MNV-1C

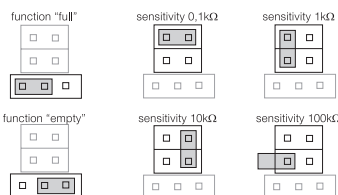
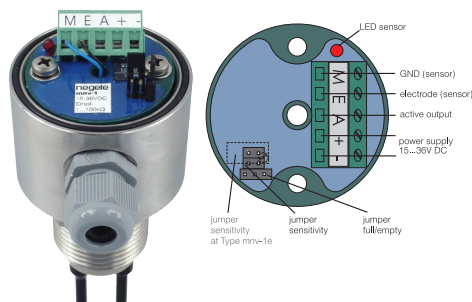

Example for the calculation of the minimum conductivity with NVS-345.2/M

Distance a = 2,5 cm; factor K: 1,5 / cm
 maximum resistance R_{max} : 100 kOhm
 minimum conductivity con_{min} : 1/100 kOhm
 = 10 μ S

specific minimum conductivity of the medium:
 $con_{min} (\mu S) \times K (1/cm)$
 = 10 μ S x 1,5 / cm = 15 μ S/cm

If the conductivity of your medium is lower than the calculated value, the NVS-345.2/M can be used if you enlarge the bright area of the rod.

NVS-345.2/M



Product Information NVS-345, -50, -110, -120

Dimensioned Drawings of NVS

NVS-345

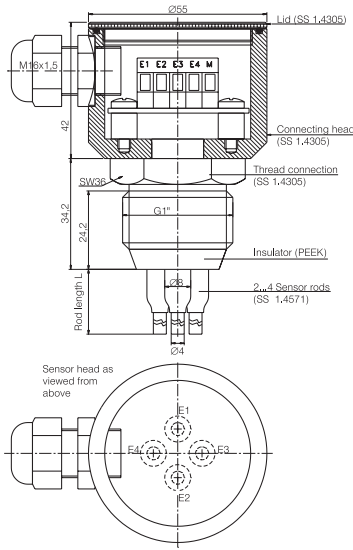

NVS-345.2/M

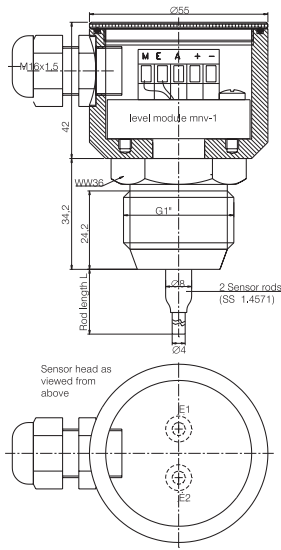

NVS-50

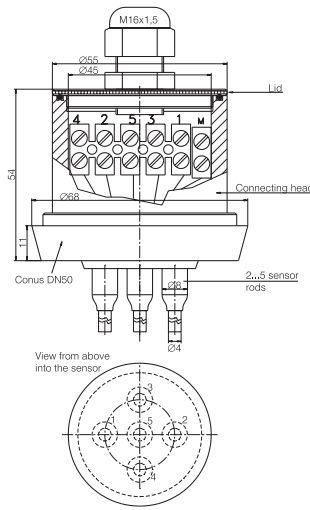

NVS-50.2/M

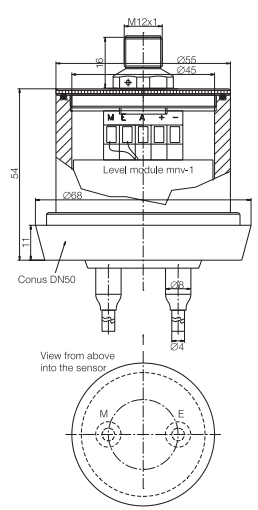

NVS-110

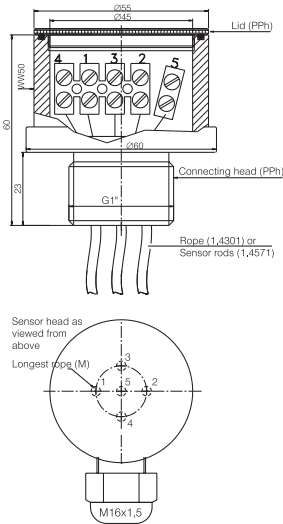

NVS-110.2/M

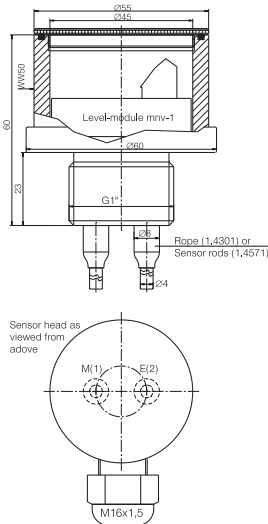

NVS-120

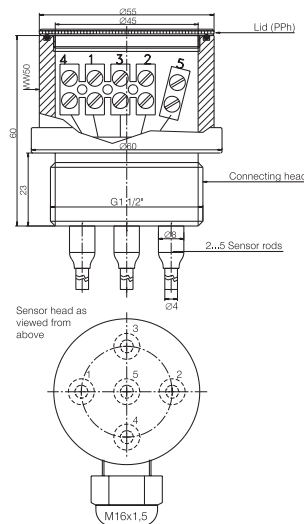

NVS-120.2/M

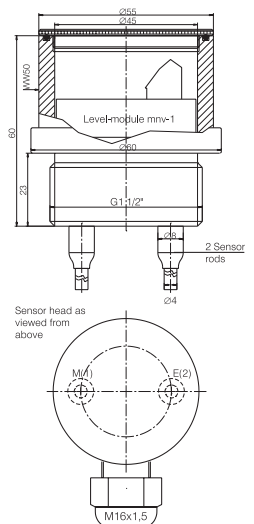

Startup the Level Sensor

- If necessary cut the electrode to the length you need. Take care that the compound between rod and sensor is not stressed to much. Do not damage the coating of the rod on the sensor side!
- Strip the isolation of coated rods at the sensor tip. 5mm are most time enough.
- Screw the sensor into the fitting. Electrical connection according to the upper drawings. Take care of the coating when you mount the sensor!

Startup the level transmitter MNV-1C

- connect the module to power supply
- setup the switching logic (description see page 2)
- select the lowest sensitivity (0,1k) (description see page 2)
- wetting the electrode with the medium with the lowest conductivity
- if the output is switching, the setup is finished
- if the output is not switching, increase the sensitivity until the output is switching. Setup is finished.

Electrical connection via M12 plug-in



Mounting Instructions

- **Only use Negele weld-in systems for the NVS-345, to ensure a save function of the measurement point!**
- Take attention of the maximum torque when you build in the sensor (see the specification on page 2)!
- If the vessel wall should be used as ground, the vessel must be of metal (only possible with NVS-345 and NVS-50). In this case a good electrical connection between the fitting and the thread connection of the sensor is necessary. **Do not use any kind of sealing band** like e.g. Teflon tape!
- Before mounting the sensor please take attention that the electrodes will emerge if the vessel gets empty.
- For mounting and demounting the sensor, please use the spanner flat only! Do not use the connection head!



Product Information NVS-345, -50, -110, -120



Order Code

Type	Electrodes	Rod length 1 / 2 / 3 / 4 / 5	Rods coated	Level modul (with MNV-1C)**	open circuit alarm**	Electrical connection
Model: with hygienic thread connection G1", connection head of stainless steel						
NVS-345	.2 (2 rods) .3 (3 rods) .4 (4 rods)	200; 500; 850; 1000; 1500; 2000 mm*	B (coated) N (bright)	X (without) M (with MNV-1C)**	X (without) D (100 kOhm, only without MNV)**	X (M16x1,5) M12 (M12-plug)
Model: with diary flange DN50 acc to. DIN11851, connection head of stainless steel						
NVS-50	.2 (2 rods) .3 (3 rods) .4 (4 rods) .5 (5 rods)	200; 500; 850; 1000; 1500; 2000 mm*	B (coated) N (bright)	X (without) M (with MNV-1C)**	X (without) D (100 kOhm, only without MNV)**	X (M16x1,5) M12 (M12-plug)
Model: with G1" standard thread connection, connection head of plastic (PP)						
NVS-110	.2 (2 rods) .3 (3 rods) .4 (4 rods) .SEIL (rope-electrodes)	200; 500; 850; 1000; 1500; 2000 mm*	B (coated) N (bright)	X (without) M (with MNV-1C)**	X (without) D (100 kOhm, only without MNV)**	X (M16x1,5) M12 (M12-plug)
Model: with G1 1/2" standard thread connection, connection head of plastic (PP)						
NVS-120	.2 (2 rods) .3 (3 rods) .4 (4 rods) .5 (5 rods)	200; 500; 850; 1000; 1500; 2000 mm*	B (coated) N (bright)	X (without) M (with MNV-1C)**	X (without) D (100 kOhm, only without MNV)**	X (M16x1,5) M12 (M12-plug)

Order example: **NVS-345.2 / 200B / 200B / M / X / M12**

* Special lengths on request
** Only possible for sensors with 2 rods

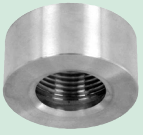
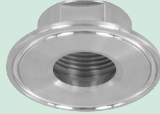
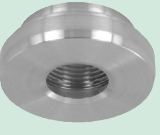
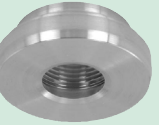
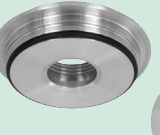
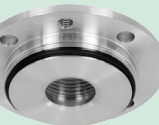
Overview of all available process connections for NVS-345

Thread size	Negele weld-in sleeve	TriClamp	Diary flange (DIN 11851)	DRD (press ring opt. available)	Varivent-Inline	APV-Inline	Adapter G1 1/2" / G1"
G1" Adapter							
Pipe size	EMZ-352 (only one size)	AMC-352/1"-1,5" AMC-352/1"-1,5" AMC-352/2" AMC-352/3" AMC-352/80 AMC-352/4"	AMK-352/25 AMK-352/40 AMK-352/50 AMK-352/65 AMK-352/80 AMK-352/100	AMK-352/50 (only one size)	- AMV-352/40 AMV-352/40 AMV-352/40 AMV-352/40 AMV-352/40	- AMA-352 AMA-352 AMA-352 AMA-352	AMG-352/ G1,5" (Adapter G1 1/2" > G1" hygienic)
Order example: Adapter: G1" to APV-Inline DN100:	AMV-352 / 40						

Further process connections on request: SMS, RJT, IDF, DIN and ISO flanges.

Overview: external level switches for conductive level sensors (for rail mounting)

Technical Data: please see the product information 'External level switches for conductive level sensors'



VNV-E

VNV-D

ZNV-Z

VNV-V

VNV-S

VNV-WEV

VNV-WD