

2-1/2" ~ 4"

圖面
92.11.28
確認章

管
制
文
件

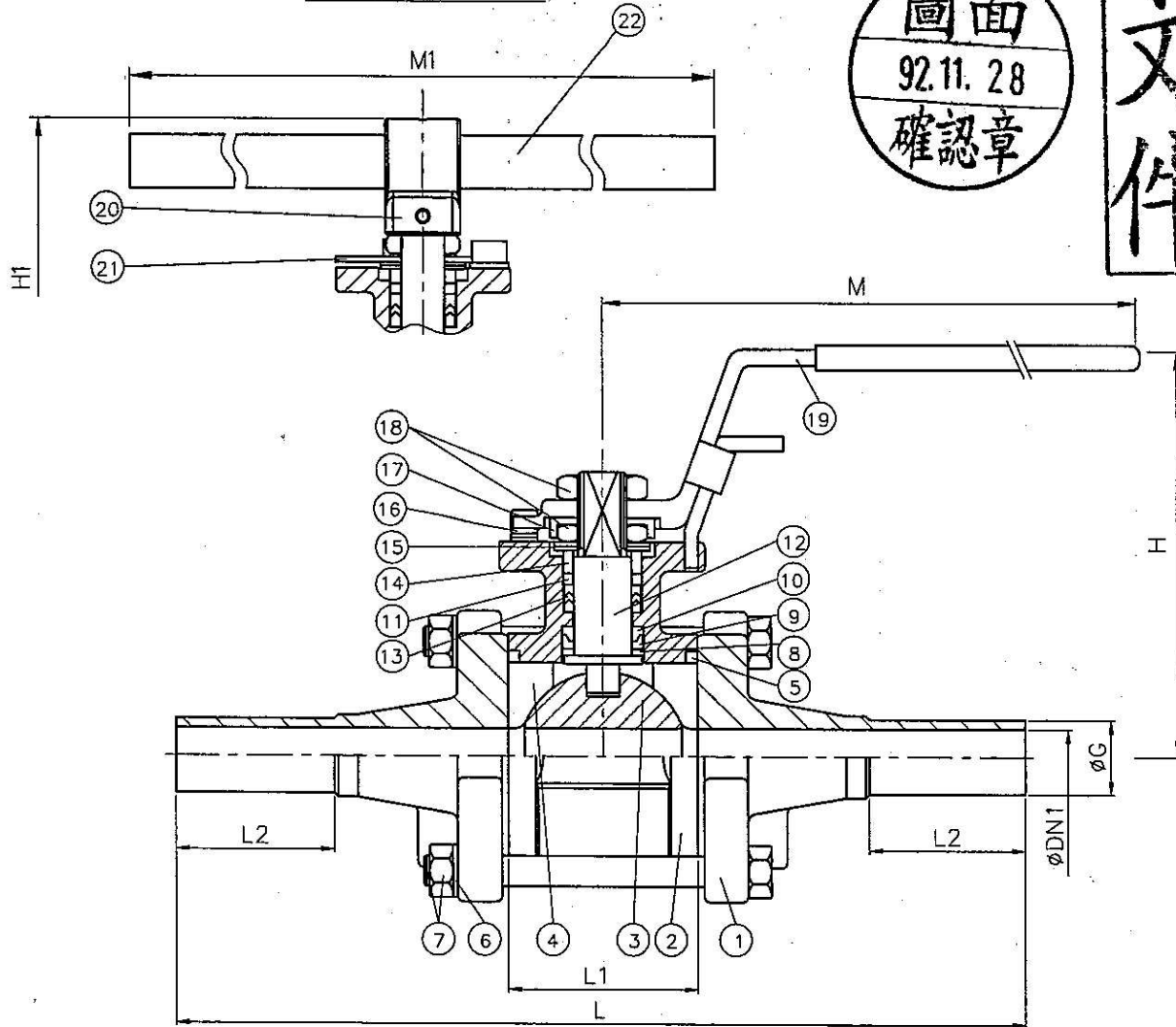

NO.	PART NAME	MATERIAL	Q'TY
1	CAP	CF3M	2
2	BODY	CF8M	1
3	BALL	CF8M	1
4	BALL SEAT	PTFE	2
5	BODY GASKET	PTFE	2
6	BOLT WASHER	SUS304	4
7	BOLT&BOLT NUT	A194 Gr.B8	4
8	LOWER THRUST WASHER	50% SS/50% PTFE	1
9	COMPRESS RING	SUS316	1
10	UPPER THRUST WASHER	TFM1600	1
11	THRUST WASHER	50% SS/50% PTFE	1
12	STEM	SUS316	1
13	V-RING STEM PACKING	PTFE	1S.
14	GLAND	SUS304	1
15	BELLEVILLE WASHER	SUS301	2
16	STOP BOLT	SUS304	1
17	LOCK SADDLE	SUS304	1
18	STEM NUT	SUS304	2
19	HANDLE	CF8	1
20	STEM ADAPTER	CF8 (2-1/2"~4")	1
21	TRIANGLE STOPPER	SUS304 (2-1/2"~4")	1
22	HANDLE	SGP Zn PLATING (2-1/2"~4")	1

SIZE	L	L1	L2	M	M1	H	H1	φDN1	φG
1/2"	139.7	26.5	35	135	N/A	86.5	N/A	10.22	12.7
3/4"	139.6	33.2	36	135	N/A	90	N/A	15.75	19.05
1"	160.7	37.7	38	165	N/A	99	N/A	22.1	25.4
1-1/2"	190.4	58	46	200	N/A	117.5	N/A	34.8	38.1
2"	203.2	69.6	46	200	N/A	126.5	N/A	47.5	50.8
2-1/2"	254	86.5	56	250	495	162.5	166.5	60.2	63.5
3"	279	102.2	60	250	495	172	176	72.9	76.2
4"	307	125.4	60	N/A	595	N/A	350	97.38	101.6

REV	DATE	DESCRIPTION	CODE	REVISER	REMARKS	MATERIAL	APPROVE	CHECK	SCALE	UNIT	DATE	Q'TY	REV	0
					70T		張存玉		英明權	FREE	mm	11.28.03	JOHN	
					EXTEND BUTT-WELD							1		
						OTHER								
						DWG NO	VB-70TAH		TITLE	ASSEMBLY				
 TAIWAN VALVE CO., LTD														